



Commercial Sand Media Filter Tank Criteria for Energy Efficiency *- Agricultural Drip Irrigation*



Technical Report

**IRRIGATION
TRAINING AND
RESEARCH
CENTER**

Prepared by

Dr. Charles Burt, P.E.

Irrigation Training and Research Center (ITRC)

California Polytechnic State University

San Luis Obispo, CA 93407-0730

805.756.2434

www.itrc.org

Disclaimer:

Reference to any specific process, product or service by manufacturer, trade name, trademark or otherwise does not necessarily imply endorsement or recommendation of use by either California Polytechnic State University, the Irrigation Training and Research Center, or any other party mentioned in this document. No party makes any warranty, express or implied and assumes no legal liability or responsibility for the accuracy or completeness of any apparatus, product, process or data described previously.

Irrigation Training and Research Center

September 2010

TABLE OF CONTENTS

BACKGROUND.....	1
Media Tanks Tested	2
Exterior and Interior Views of Tanks.....	3
UNDERDRAIN CHARACTERISTICS	5
Total Slot Open Area	5
Horizontal Distribution of the Slots across the Bottom of the Tanks.....	11
Vertical Distribution of the Slots across the Bottom of the Tanks.....	13
HYDRAULIC CHARACTERISTICS	14
Media Description	17
Pressure Losses through the Underdrain (No Media)	18
Pressure Loss through the Media	19
Pressure Loss through the Backflush Valves	20
Combined Pressure Loss	21
Activation Pressures and Times for Backflush Valves	22
VISUAL INSPECTION OF THE TOP OF THE MEDIA BED AFTER BACKFLUSH.....	24
DISCHARGE OF MEDIA DURING BACKFLUSH	26
TESTING WITH CONTAMINANTS	27
Contaminant Description.....	27
Backflushing of Contaminants.....	29
Contaminant Retained in the Media.....	30
BACKFLUSH PRESSURE VERSUS FLOW RATE.....	32
SUMMARIZED OBSERVATIONS	33
ENERGY IMPLICATIONS.....	35

LIST OF FIGURES

Figure 1. Arkal AGF exterior and underdrain	3
Figure 2. Flow-Guard exterior and underdrain.....	3
Figure 3. Lakos exterior and underdrain	3
Figure 4. Waterman Wand (“spike”) exterior and underdrain	4
Figure 5. Waterman Dome exterior and underdrain.....	4
Figure 6. Example micro drill bits.....	5
Figure 7. Arkal pod design. The photo with the pod arms shows a broken pod	6
Figure 8. Flow-Guard underdrain. Pods are found under the flat stainless disks.....	7
Figure 9. Lakos underdrain. The longest wands have a non-perforated PVC pipe section near their inlets.....	8
Figure 10. Waterman Dome underdrain. The pods are at different heights, due to the shape of the inverted dome. Photo shows at least 3 locations where pods were expected to be found but were not installed.....	9
Figure 11. Waterman Wand (“spike”) underdrain. The top wands are shorter than the lower ones; slots are found along the complete length of each wand.....	10
Figure 12. Arkal pod arrangement.....	11
Figure 13. Flow-Guard pod arrangement	11
Figure 14. Lakos open wand arrangement	12
Figure 15. Waterman Dome pod arrangement	12
Figure 16. Waterman Wand arrangement.....	12
Figure 17. Schematic of the test setup for test with clean water	14
Figure 18. Test layout for dirty water testing	14
Figure 19. Locations of pressure measurements	15
Figure 20. Measurement locations during filtration process	15
Figure 21. Measurement locations during backflush process.....	16
Figure 22. Pressure loss in the underdrain during filtration	18
Figure 23. Pressure loss in the underdrain during backflush.....	18
Figure 24. Pressure loss through the media during filtration mode. Clean media and water.....	19
Figure 25. Pressure loss through the media during backflush mode. Clean media and water.....	19
Figure 26. Friction loss through the backflush valves – filtration mode	20
Figure 27. Friction loss through the backflush valves – backflush mode	20
Figure 28. Total pressure loss across tanks with clean water and media – filtration mode.....	21
Figure 29. Total pressure loss across tanks with clean water and media – backflush mode	21
Figure 30. Schematic of the test setup with backflush valve closed	22
Figure 31. Schematic of the test setup with backflush valve open (actuated).....	22
Figure 32. Arkal AGF-48” media bed after media cleaning	24
Figure 33. Flow-Guard media bed after media cleaning	24
Figure 34. Lakos media bed after media cleaning.....	25
Figure 35. Waterman Wand (“spikes”) bed after media cleaning	25
Figure 36. Waterman Dome bed after media cleaning	25
Figure 37. Examples of large amounts of media removed during backflush	26
Figure 38. Example data collected during filtration with contaminant	27
Figure 39. Potting soil caught on inlet dissipation screen of the Lakos media tank. Flow- Guard has a similar dissipation screen, but was not tested with potting soil	28
Figure 40. Potting soil that accumulated on the top of the media bed, even after repeated backflushing	28
Figure 41. Number of backflushes per day – Lakos.....	29

Figure 42. Number of backflashes per day – Flow-Guard30
Figure 43. Plastic template used to position sampling cores across the top of the media30
Figure 44. PVC cores forced 4” deep into each hole in the template, with collected soil.....31
Figure 45. Duration of filtration compared to number of backflashes, showing that the pressure at the bottom of the filter does not impact dirt removal, if the flow rate remains constant.....32

LIST OF TABLES

Table 1. Information supplied by manufacturers.....2
Table 2. Underdrain slot characteristics5
Table 3. Horizontal area served by underdrain units.....13
Table 4. Fraction of the horizontal area covered by pods or slotted wands13
Table 5. Minimum and maximum backflush valve closure times and pressures23
Table 6. Sand collected during backflush tests.....26
Table 7. Contaminants injected during 15-day tests.....27
Table 8. Contaminant analysis from sand media.....31
Table 9. Characteristics of the media filter tanks33

BACKGROUND

Sand media filters are commonly used in agricultural drip irrigation systems. They have the advantages of simplicity and large capacities, and are favored by many farmers and designers over other filtration hardware.

The primary justification for the research described in this report was to determine if it is possible and reasonable to use lower-than-accepted backflush pressures and thereby reduce the total pressure requirement for drip systems. Common design lore by manufacturers and irrigation dealers indicates that for media filters to backflush properly, at least 30–35 psi is needed downstream of the filters. This high pressure requirement can exceed what is needed for the combination of other system components and conveyance within a drip system – especially for row crop drip systems that have tapes operating in the 8–10 psi range.

ITRC designed and performed a series of hydraulic tests on several different commercial sand media filter tanks (one unit of each of five models). The testing provided the following results:

1. There are substantially different friction losses across filters of different designs at different times:
 - a. During backflush
 - b. During filtration
2. The primary pressure loss location is the backflush valves.
3. Large backflush flow rates can be accomplished at relatively low backflush pressures. This assumes correct backflush water discharge piping.
4. There are substantial differences between underdrains of various media tank models, regarding:
 - a. The percent open area
 - b. The uniformity of the sizes of the openings in the slots/wands
 - c. The configurations of the slots/wands, including:
 - i. Positioning of slots/wands around the bottom of the tanks
 - ii. Height of slots/wands within the tanks
5. No large initial high pressure was necessary during the ITRC testing to “break up the media bed” when backflush began.
6. Different underdrain designs create different patterns of cleaning the media.
7. There were substantial differences between models, regarding the amount of sand discharged from the system at a backflush flow rate of 190 GPM.

Media Tanks Tested

Five different tanks were obtained from four manufacturers. Only two tanks were tested over an extended period of time with contaminants, due to the complexity of those tests and the large amount of time needed. The various tanks are described individually below. Lakos later provided a tank with a modified, newer underdrain for some tests (listed as “newer design” in this report).

Manufacturers modify their designs over time, and these tests were meant to investigate various designs – as opposed to attempting to compare manufacturers. Also, considerations such as corrosion, strength of tanks, longevity of valve actions, sensitivity to damage during transportation, and cost were not evaluated in this project. The intents of this publication are to increase awareness of how these important filters work, and to indicate factors that might be modified to improve their performance.

Table 1 provides basic information for each tank. All tanks were 48” nominal diameter, and rated at 80 psi by the manufacturers.

Table 1. Information supplied by manufacturers

	Arkal (Netafim)	Flow-Guard (Fresno Valves & Castings)	Lakos	Waterman	Waterman
Model	AGF – 48”	SS – 48”	SST – 48”	Wand	Dome
Underdrain material	Plastic	Stainless steel	PVC plastic	Plastic	Plastic
Backflush flow rate (GPM)	176 - 264	200	188	Not provided	Not provided
Filtration flow rate (GPM)	220 – 313	213 – 313	220 – 313	Not provided	Not provided
Minimum backflush pressure (psi)	28	Not provided	20 – 80	Not provided	Not provided
Media sand requirement (lb)	1200	1300	1300	800*	800
Gravel requirement (lb)	None	560	None	Not stated	Not stated

*The Waterman Wand had a recommendation of 800 lb of media, but ITRC added an additional 7.5 cm. of media depth to provide cover over the wands. The 800 lb would have only provided 2.5 cm of cover at the most shallow point.

Exterior and Interior Views of Tanks

Figures 1 through 5 show the various tanks that were tested.



Figure 1. Arkal AGF exterior and underdrain



Figure 2. Flow-Guard exterior and underdrain



Figure 3. Lakos exterior and underdrain



Figure 4. Waterman Wand (“spike”) exterior and underdrain



Figure 5. Waterman Dome exterior and underdrain

These photos provide views of the underdrain designs and positioning near the base of the tanks. ITRC noticed the following upon delivery of the tanks:

1. The Waterman Dome appeared to be missing several pods, as can be seen in **Figure 5**. The tank was tested as-is.
2. One of the pods for the Arkal filter was broken. That pod was replaced before testing.

UNDERDRAIN CHARACTERISTICS

Total Slot Open Area

Micro drill bits (e.g., Item #08WS97-90 from Drill Bit City) were used to measure underdrain slot open widths. Approximately 120 measurements were made for each filter. Because the drill bits have discrete sizes, the accuracies of the slot width measurements are only within +/-2%.

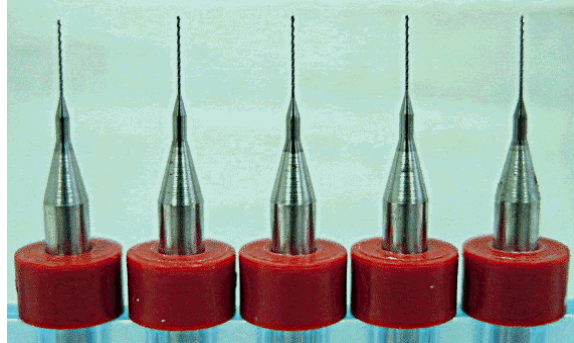

Figure 6. Example micro drill bits

At the start of the testing, it was thought that the total slot open area might be an important indicator of:

1. Pressure requirements for backflushing.
2. Uniformity of cleaning the media bed during backflush.

Table 2 provides a summary of measurements regarding the underdrain slots. It can be seen that there are substantial differences in:

1. *Total slot open area.*
2. *Standard deviation of slot widths* (a large standard deviation indicates large differences in slot widths; with a “normal” distribution of widths, 95% of all slot widths should fall within +/- 2 standard deviations of the mean). Statistically speaking, one might expect 95% of all Flow-Guard slot sizes to fall between 0.165 mm – 0.291 mm. In fact, the absolute range of all measured sizes was 0.180 mm – 0.279 mm.
3. *Mean slot widths.* It might be noted that a large total slot area can be achieved by having a relatively smaller number of slots.

Table 2. Underdrain slot characteristics

Tank	Total # of pods or screen sections	Mean slot width, mm.	Std. dev. of widths, mm.	Total slot open area, sq. cm.
Arkal	55	0.330	0.036	200
Flow-Guard	19	0.233	0.029	184
Lakos (original)	27	0.307	0.107	405
Lakos (newer design)	25	0.273	0.036	261
Waterman Dome	45	0.292	not meas.	108
Waterman Wand	16	0.189	0.026	343

Figures 7-11 show close-up views of each underdrain pod or screen section.

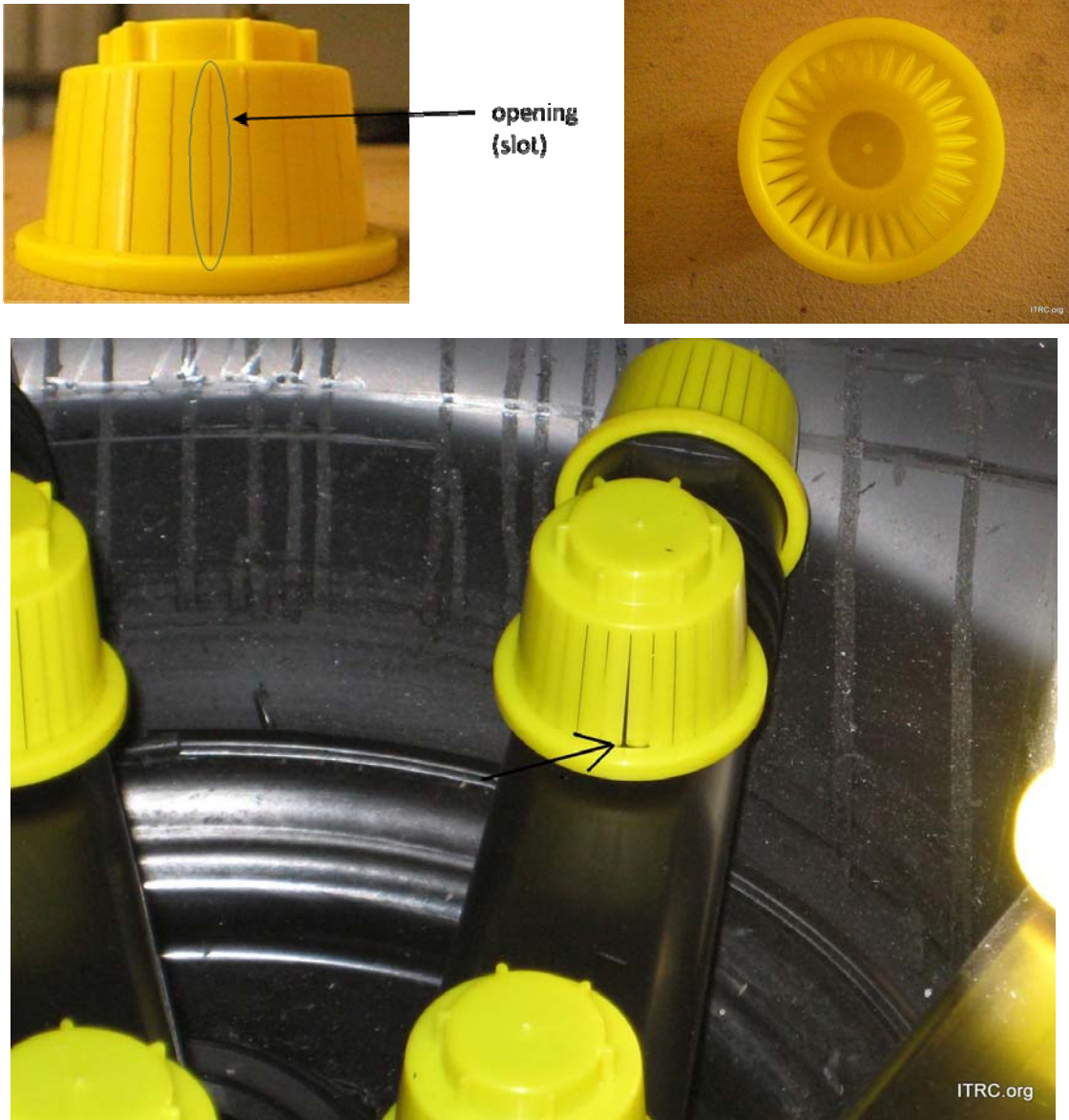

Figure 7. Arkal pod design. The photo with the pod arms shows a broken pod



Figure 8. Flow-Guard underdrain. Pods are found under the flat stainless disks.

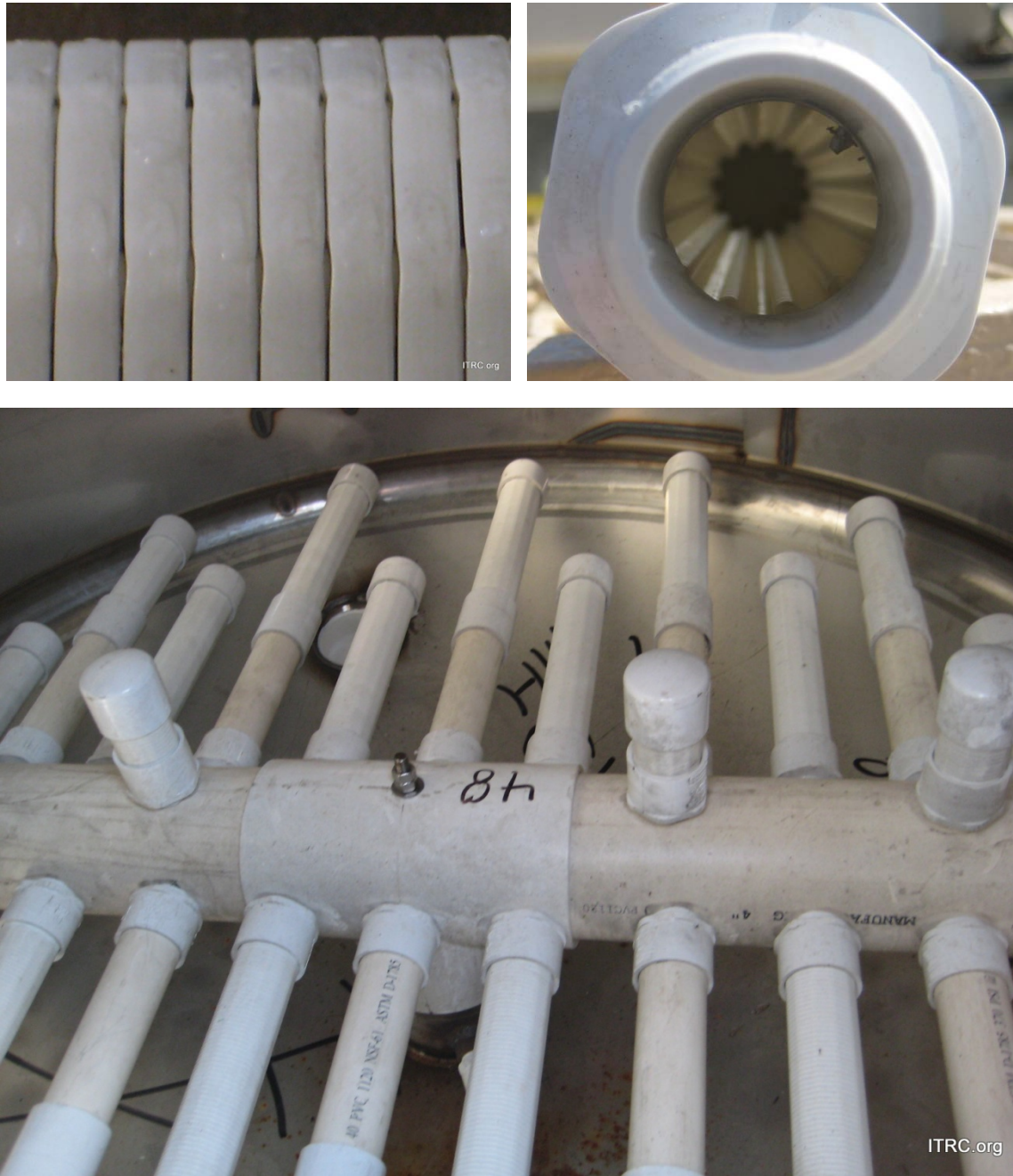

Figure 9. Lakos underdrain. The longest wands have a non-perforated PVC pipe section near their inlets.

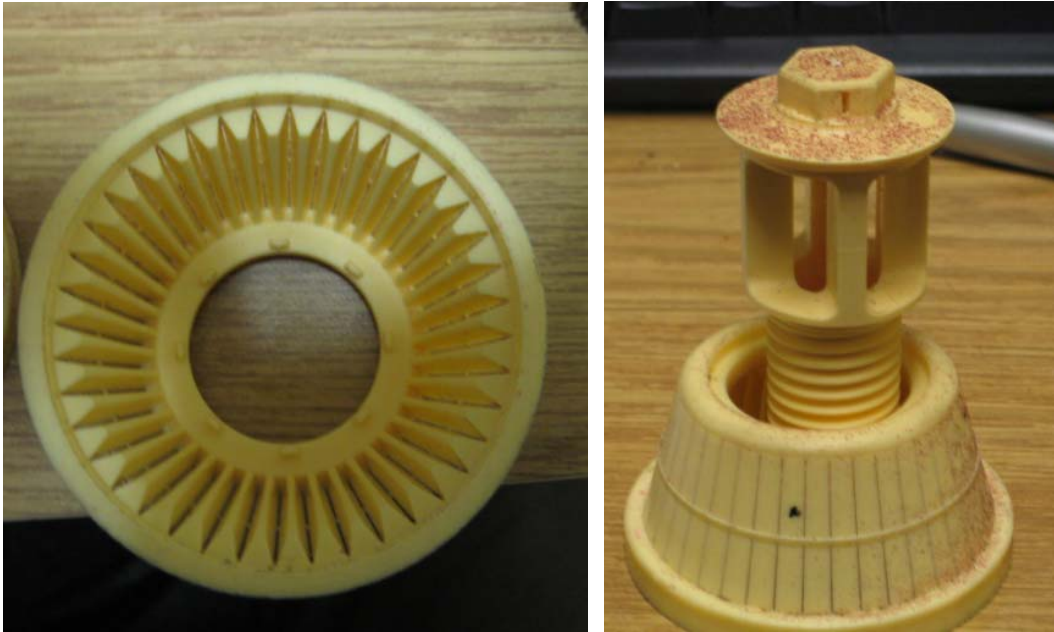

Figure 10. Waterman Dome underdrain. The pods are at different heights, due to the shape of the inverted dome. Photo shows at least 3 locations where pods were expected to be found but were not installed.

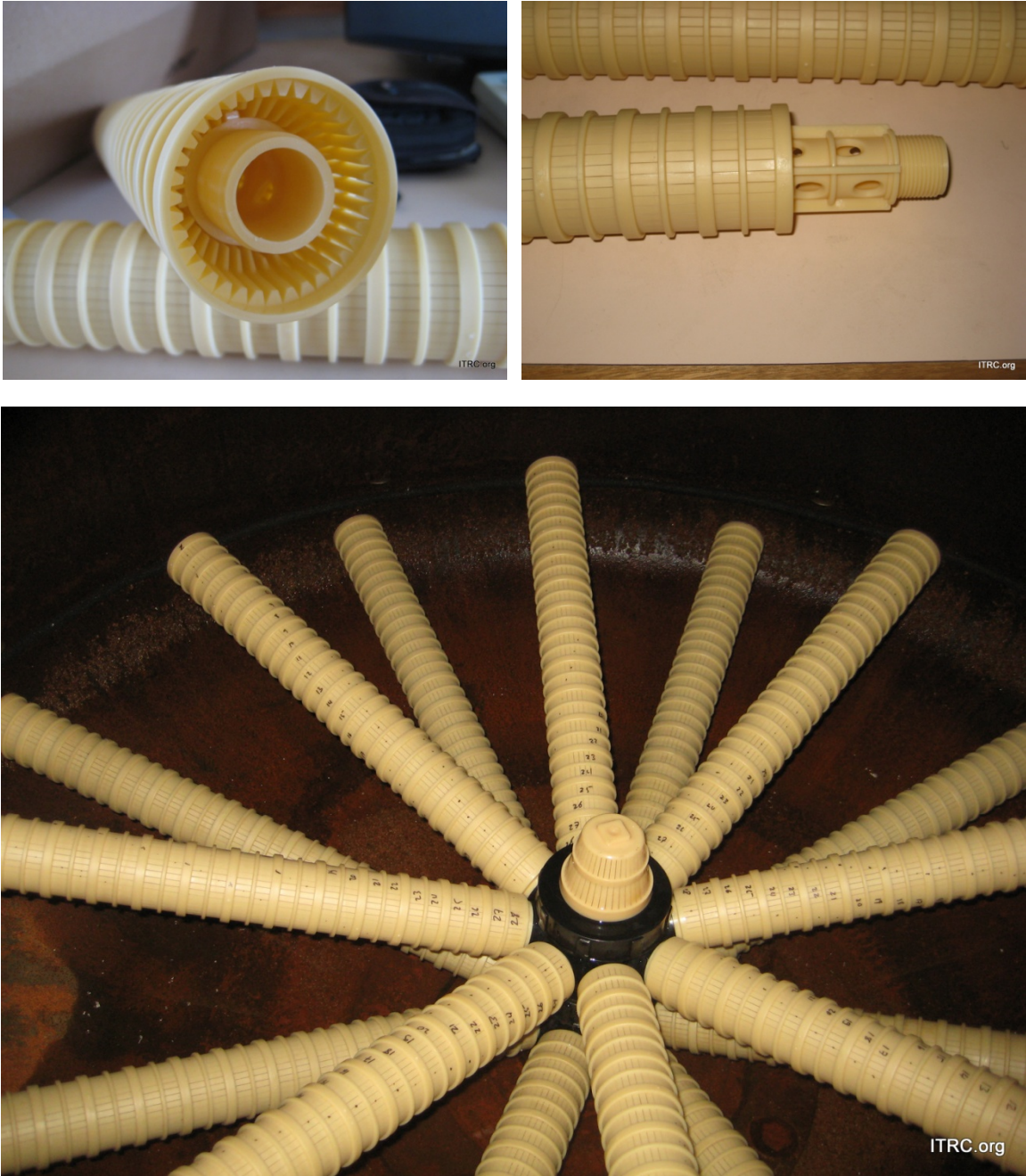

Figure 11. Waterman Wand (“spike”) underdrain. The top wands are shorter than the lower ones; slots are found along the complete length of each wand.

Horizontal Distribution of the Slots across the Bottom of the Tanks

It was hypothesized at the start of the tests that an even and dense distribution of slots across the bottom of a tank would be beneficial in providing a uniform cleaning of media during backflushing.

For each of the tanks, areas of responsibility were assigned for each pod or open wand area. Sketches were developed and areas were computed, as shown in **Figures 12-16**.

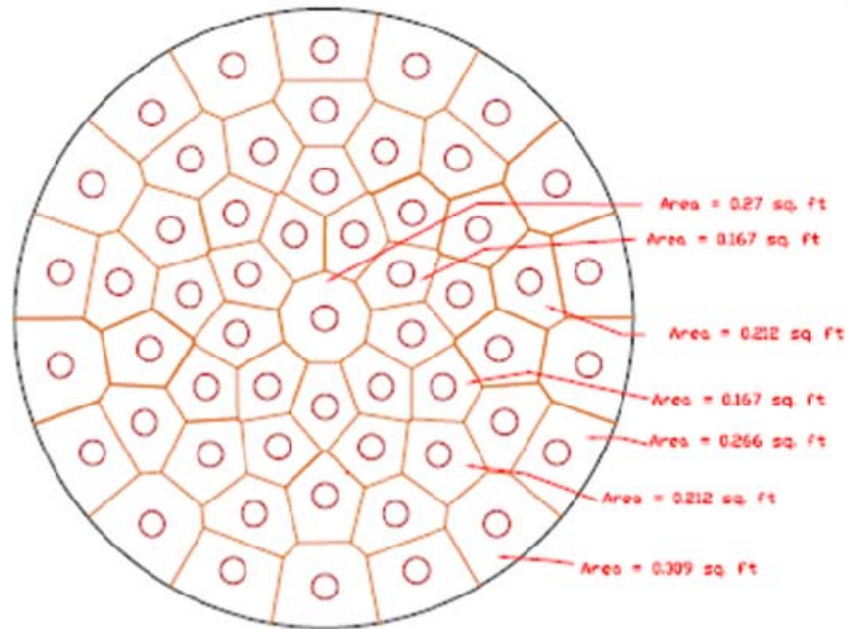

Figure 12. Arkal pod arrangement

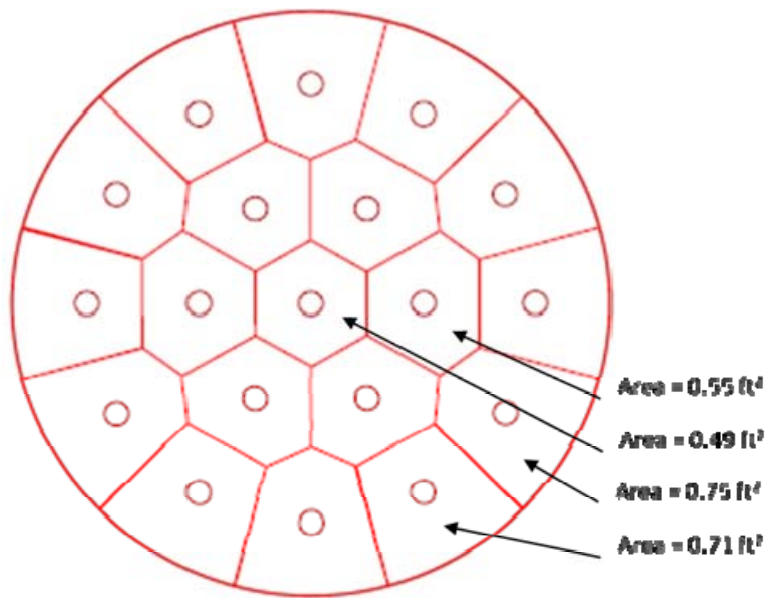

Figure 13. Flow-Guard pod arrangement

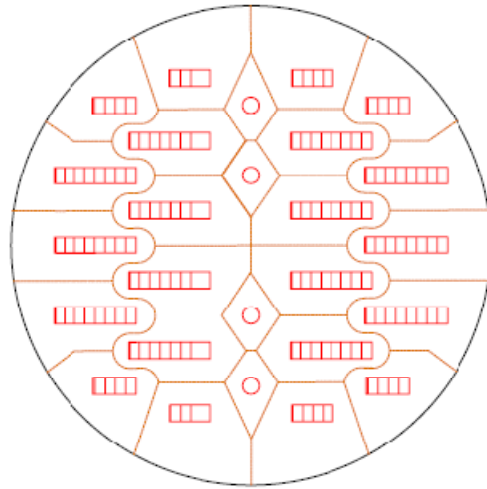

Figure 14. Lakos open wand arrangement

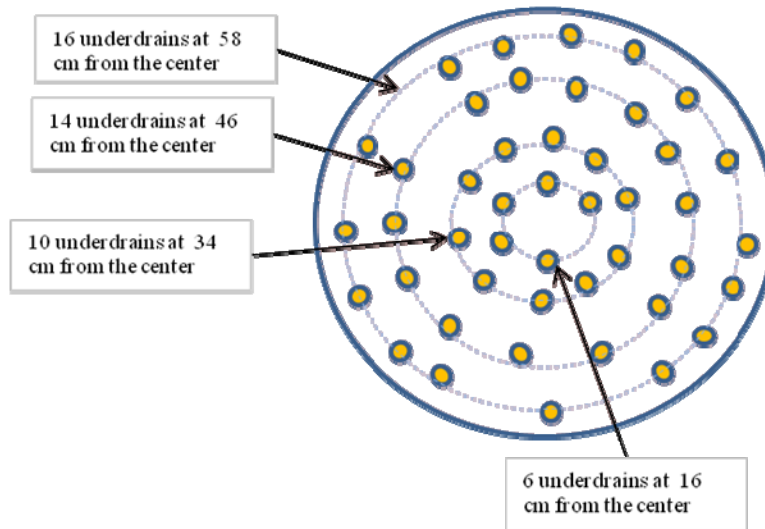

Figure 15. Waterman Dome pod arrangement

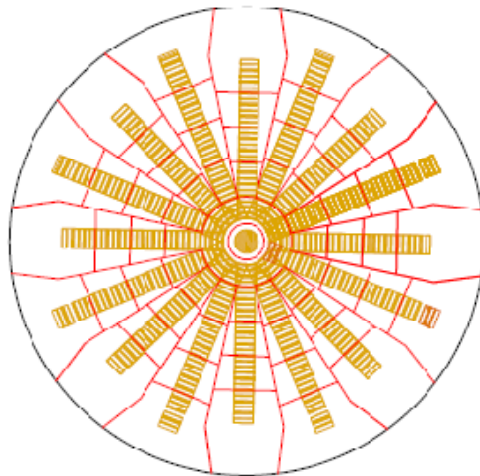

Figure 16. Waterman Wand arrangement

Table 3 shows the variation in horizontal tank area served per unit of open underdrain, for each of the models examined.

Table 3. Horizontal area served by underdrain units

	Average area served, sq. cm. per unit	cv
Arkal	214	0.24
Flow-Guard	613	0.14
Lakos	446	0.31
Waterman Dome	214	0.17
Waterman Wand	177	0.75

The “cv” in **Table 3** is the coefficient of variation, which has no units or dimensions, and is defined as:

$$cv = \frac{\text{standard deviation}}{\text{mean}}$$

where 95% of the values are expected to approximately fall within +/- two cv’s of the average. For example, if the Waterman Dome had a normal distribution of areas per pod, almost all of the values should fall between 141 cm² - 287 cm². A small cv indicates a very uniform horizontal distribution of pods/units.

The average area per unit may be misleading if examined alone. For example, a very long single wand, with many holes, might be responsible for a large area. An “Area covered ratio” was developed to indicate the percent of a horizontal plane that is occupied by pods or wands.

$$\text{Area covered ratio} = \frac{\text{Horizontal area occupied by pod or wand with slots}}{\text{Total surface area}} = \text{Fraction of a horizontal plane that is occupied by pods or slotted wands}$$

Table 4. Fraction of the horizontal area covered by pods or slotted wands

Tank	Fraction of area covered by pods or wands
Arkal	0.089
Flow-Guard ¹	0.033
Lakos	0.071
Waterman Dome	0.124
Waterman Wand	0.316

¹ For the Flow-Guard, the outside diameter of the pod was used to compute the area, rather than the much larger area of the flow distribution cap on top of the pods.

Vertical Distribution of the Slots across the Bottom of the Tanks

No measurements were made of this aspect of uniformity. One can see from the photographs in this report that for some models the pods are at similar elevations; others have substantial variation.

HYDRAULIC CHARACTERISTICS

Media tanks were examined individually for hydraulic characteristics. **Figure 17** illustrates the layout for testing with clean water. **Figure 18** is a schematic of water flow when contaminants were introduced.

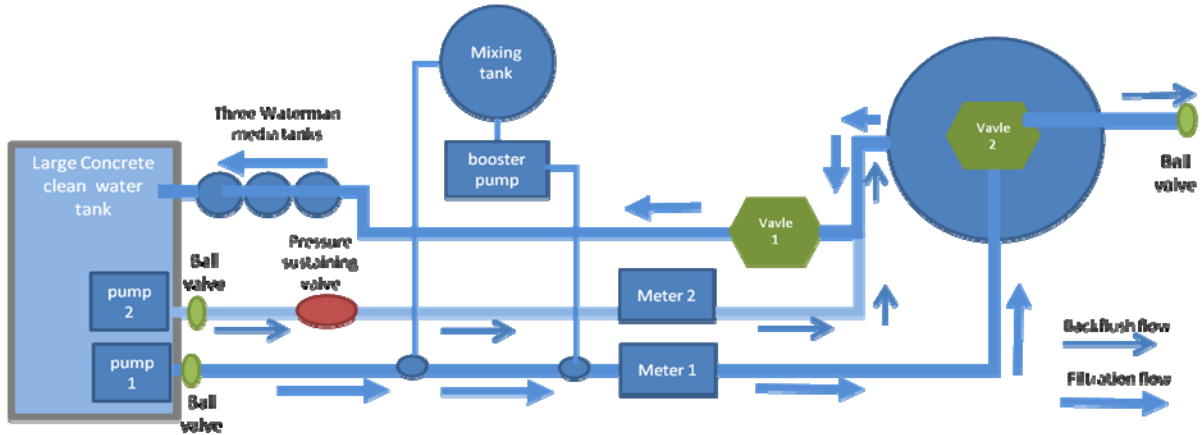

Figure 17. Schematic of the test setup for test with clean water

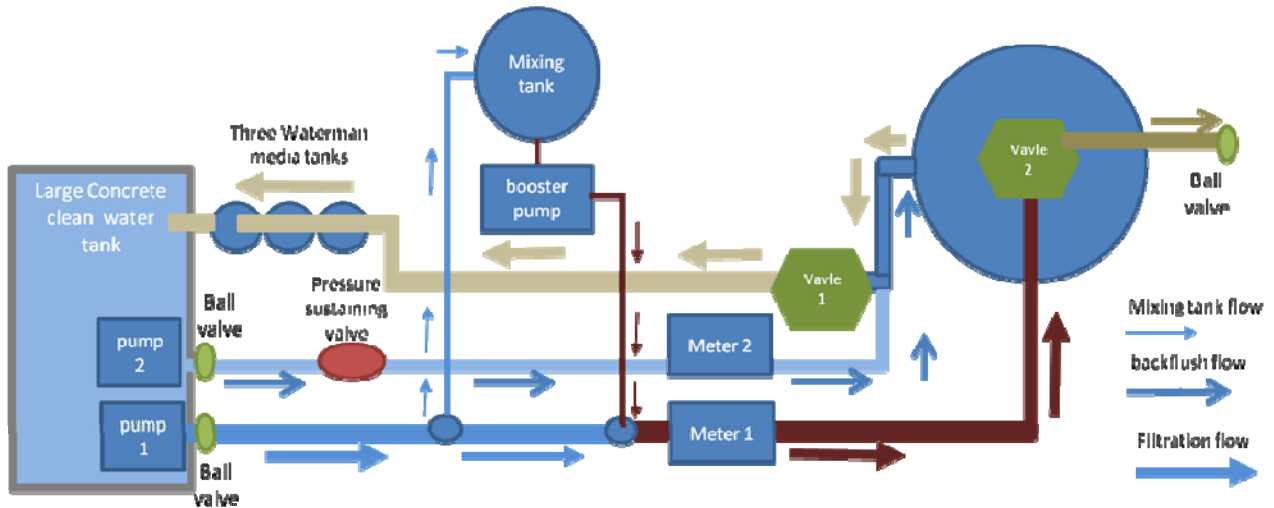

Figure 18. Test layout for dirty water testing

All pressure measurements were pressure differential pressure measurements using a high-quality pressure transducer.

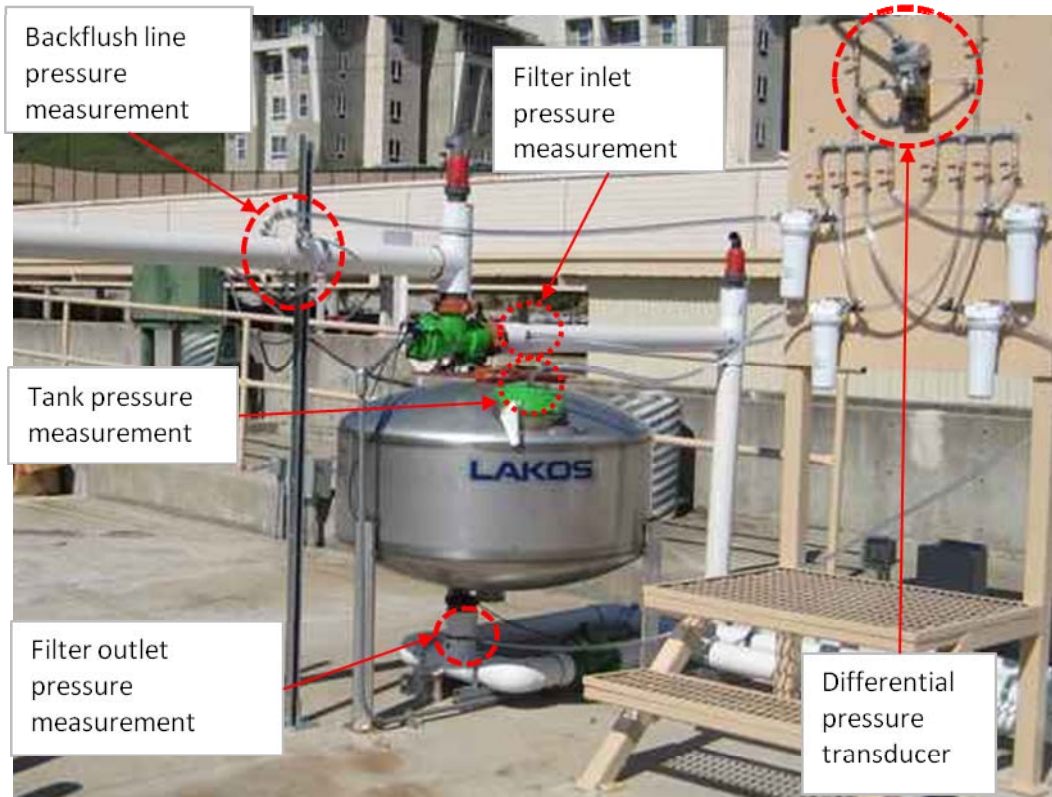

Figure 19. Locations of pressure measurements

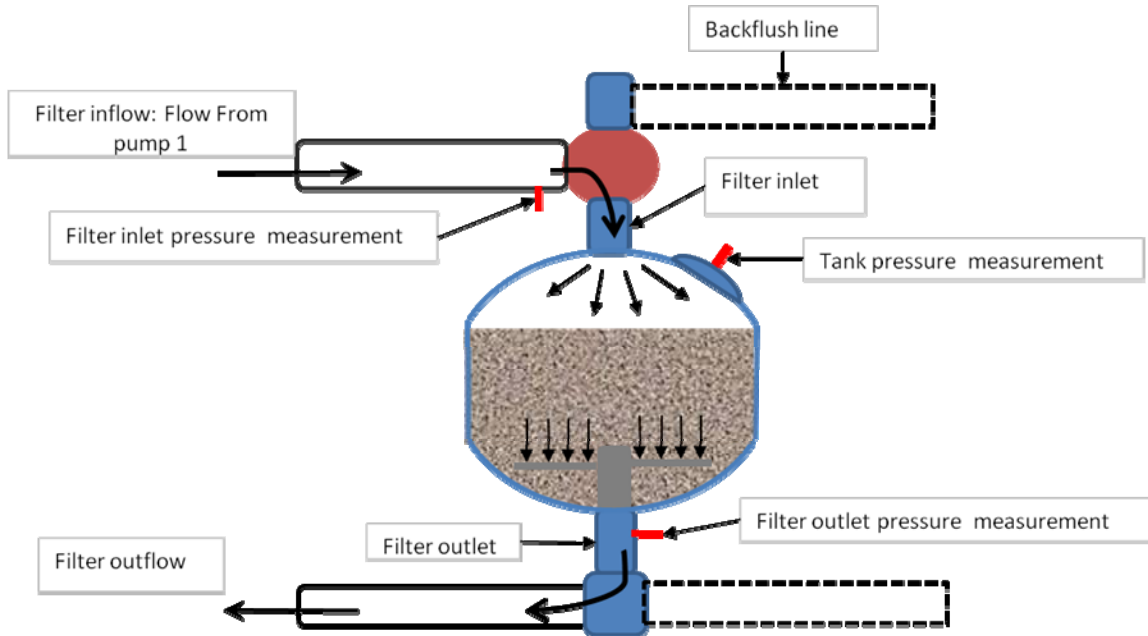

Figure 20. Measurement locations during filtration process

Figure 20 illustrates where pressure measurements were taken during “filtration”. The term “filtration” refers to the fact that water is flowing in the direction it would go, if water was being filtered. Only clean water was used for these tests. Because a pressure differential transducer was used, the “pressure loss” is technically not a “pressure loss” but rather an “energy loss”. If single transducers had been used, it would have been necessary to compensate for the elevation differences between the two transducers.

The differential pressure readings were collected as follows:

$$\text{Total pressure loss} = (\text{filter inlet pressure}) - (\text{filter outlet pressure})$$

$$(\text{Underdrain + Media}) \text{ pressure loss} = (\text{tank pressure}) - (\text{filter outlet pressure})$$

Note: This includes the loss through the media, if it was present

$$\text{Backflush valve pressure loss} = (\text{filter inlet pressure}) - (\text{tank pressure})$$

Figure 21 illustrates where pressure measurements were taken during “backflush”. The term “backflush” refers to the fact that water is flowing in the opposite direction as water being filtered. Only clean water was used for these tests.

The differential pressure readings were collected as follows:

$$\text{Total pressure loss} = (\text{filter outlet pressure}) - (\text{backflush line pressure})$$

$$(\text{Underdrain + Media}) \text{ pressure loss} = (\text{filter outlet pressure}) - (\text{tank pressure})$$

Note: This includes the loss through the media, if it was present

$$\text{Backflush valve pressure loss} = (\text{tank pressure}) - (\text{backflush line pressure})$$

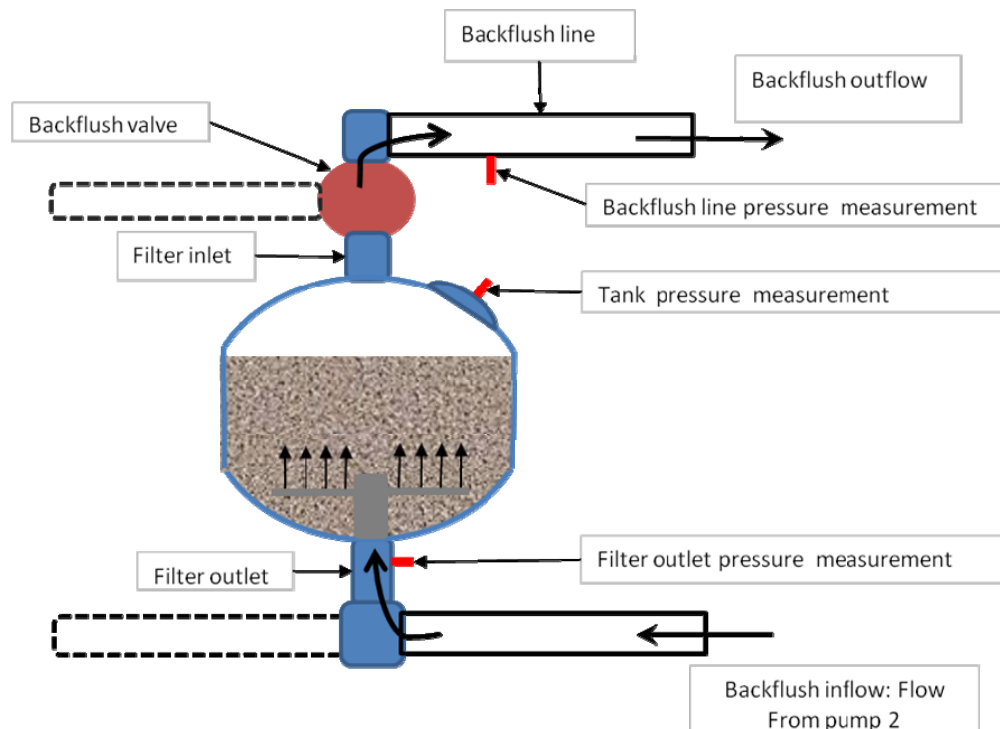

Figure 21. Measurement locations during backflush process

For the clean water tests for which media was present, the media was cleaned prior to taking measurements, using the following procedure:

1. Start with a clean filter.
2. Fill up with sand media to the manufacturer-recommended level and close fill port.
 - a. For the Flow-Guard (FV&C) tank, the gravel was placed first and cleaned with multiple backflush cycles.
 - b. The Waterman Wand tank received extra media, as noted earlier.
3. Close flow adjustment valve at Pump 2. Initial flow rate should be much lower than anticipated backflush flow rate (around 100 GPM).
4. Open backflush valve.
5. Start backflush pump (Pump 2).
6. Slowly increase the flow to the set backflush flow rate.
7. Allow pump to run for several minutes.
8. Stop pump and allow system to settle for several minutes.
9. Perform steps 3-8 at least 4 times.
10. Open the port on the filter to view the media in the tank.
11. Fill to the required level again and perform steps 3-8 one more time.
12. Open the port on the filter and view the amount of media in the tank. If it is too low, perform previous steps again until the tank contains the correct amount of clean media.

Media Description

The media was the same as that used locally by irrigation dealers. Descriptive information is:

Manufacturer: P.W. Gillibrand Company, Simi Valley, CA

Size: # 16 crushed silica

Specifications by supplier: Uniformity Coefficient = 1.42; 150-200 mesh filtration

Pressure Losses through the Underdrain (No Media)

The pressure losses through the underdrain were measured at various flow rates and in two different flow directions (Figures 22 and 23). The losses are different in the “filtration” vs. “backflush” modes because of the different nature of entrance and entrance conditions around bends and through slots.

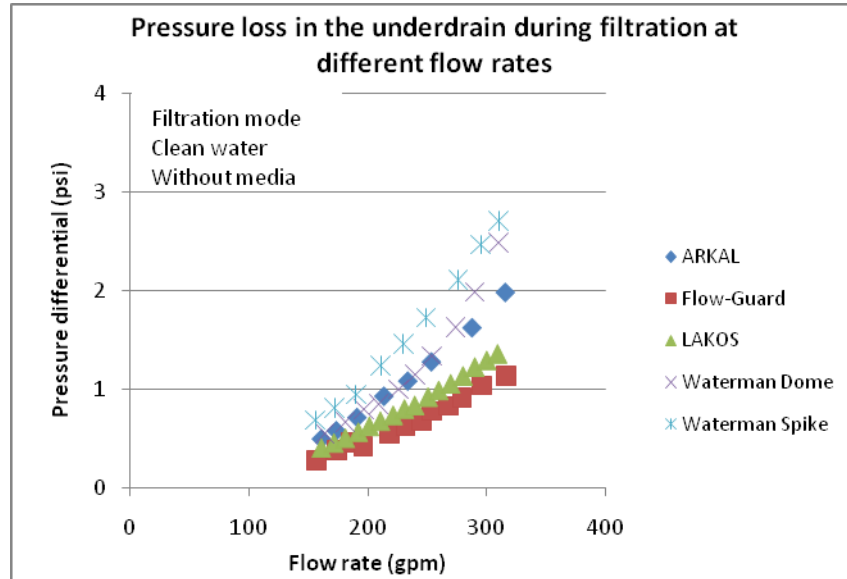

Figure 22. Pressure loss in the underdrain during filtration

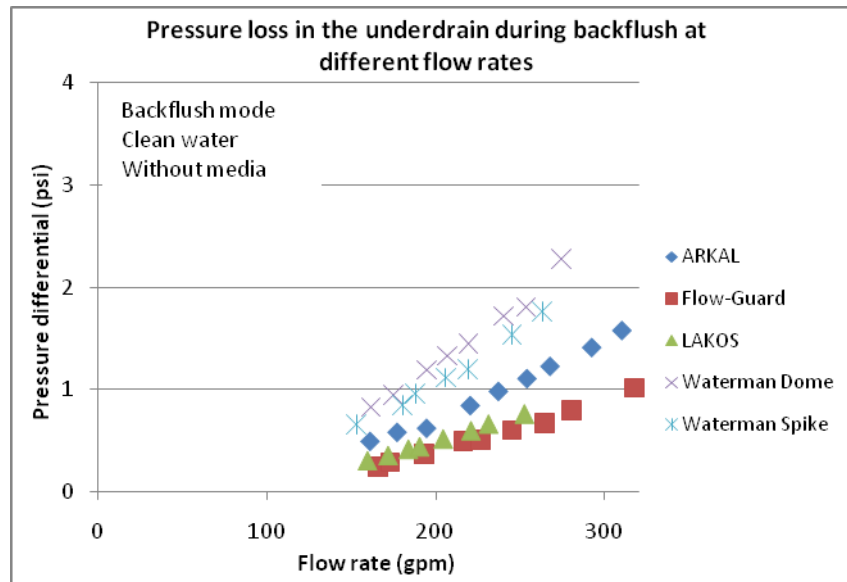

Figure 23. Pressure loss in the underdrain during backflush

Although there are differences between the various tanks, it can be seen that the underdrain loss is relatively minor when compared to the overall pressure requirement of a drip system.

Pressure Loss through the Media

The media loss was computed by finding the difference in (underdrain + media) pressures when the tests were run with and without media. **Figures 24 and 25** show the results. One would think that the loss through the media would be the same regardless of the tank, but there are differences in media height above and below the pods/wands, gravel in one tank, and different flow paths through the media depending upon the pod/wand configurations.

The pressure loss through the media during backflush shows how the loss decreases as the flow increases – due to an expanded (and therefore less restrictive) media bed.

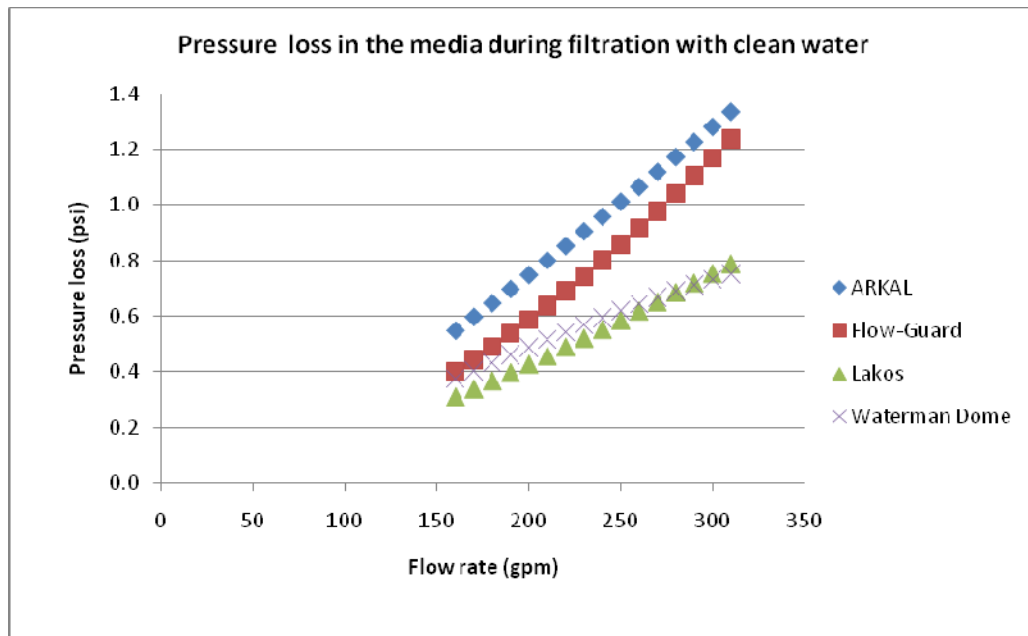

Figure 24. Pressure loss through the media during filtration mode. Clean media and water.

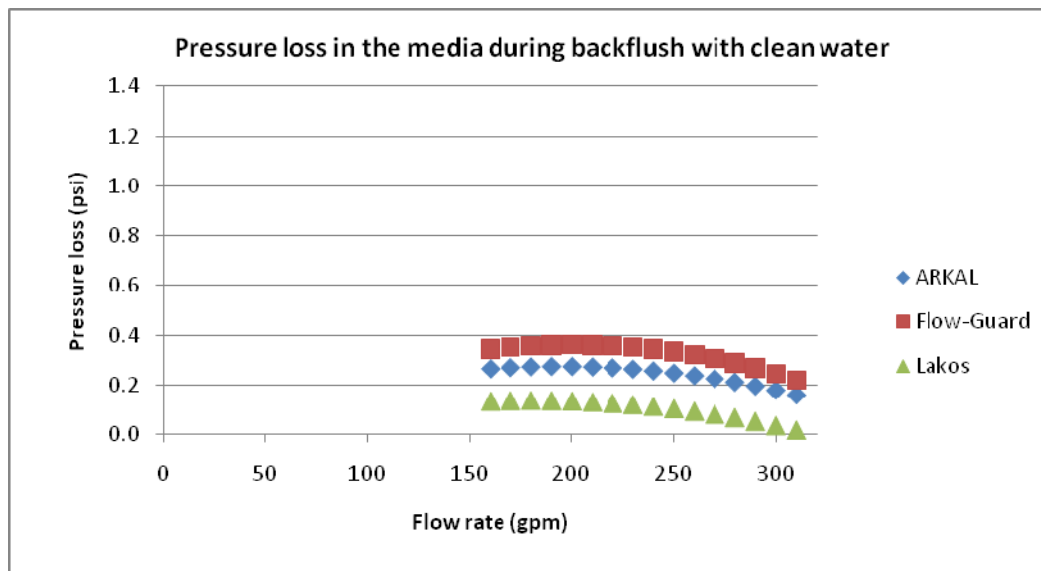

Figure 25. Pressure loss through the media during backflush mode. Clean media and water.

Pressure Loss through the Backflush Valves

The flow path configuration of the backflush valve can be quite different during backflush as compared to filtration. The impact on friction loss is clearly seen when one compares the results in **Figures 26 and 27**.

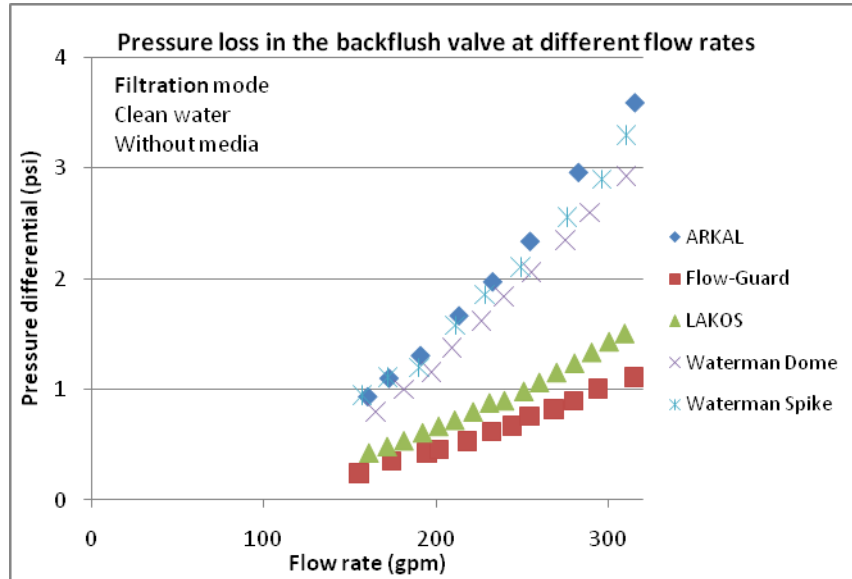

Figure 26. Friction loss through the backflush valves – filtration mode

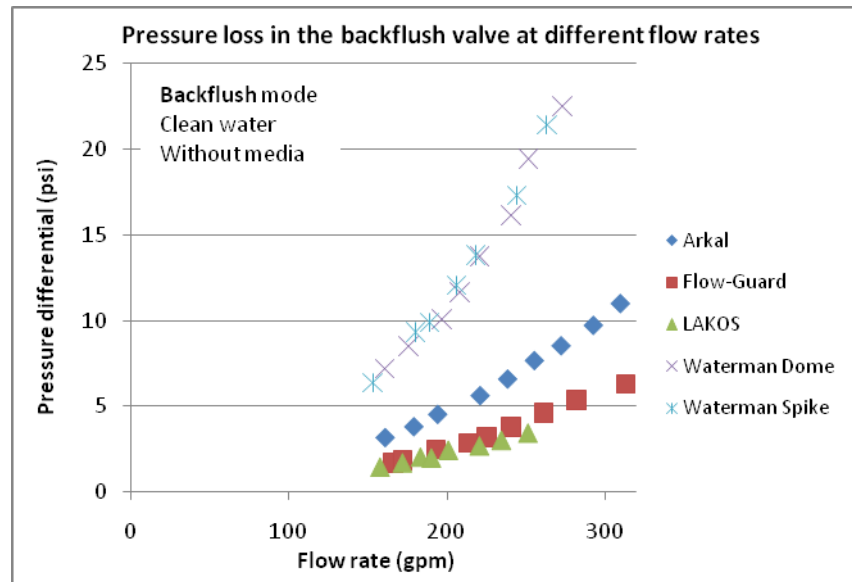

Figure 27. Friction loss through the backflush valves – backflush mode

It is clear that some of the backflush valves have hydraulic characteristics during the backflush mode that require much more pressure for backflushing than other valves. This characteristic dominates the hydraulic pressure requirements for backflushing – when considering only the tank.

Combined Pressure Loss

Figures 28 and 29 show the combined energy loss across the tanks with media.

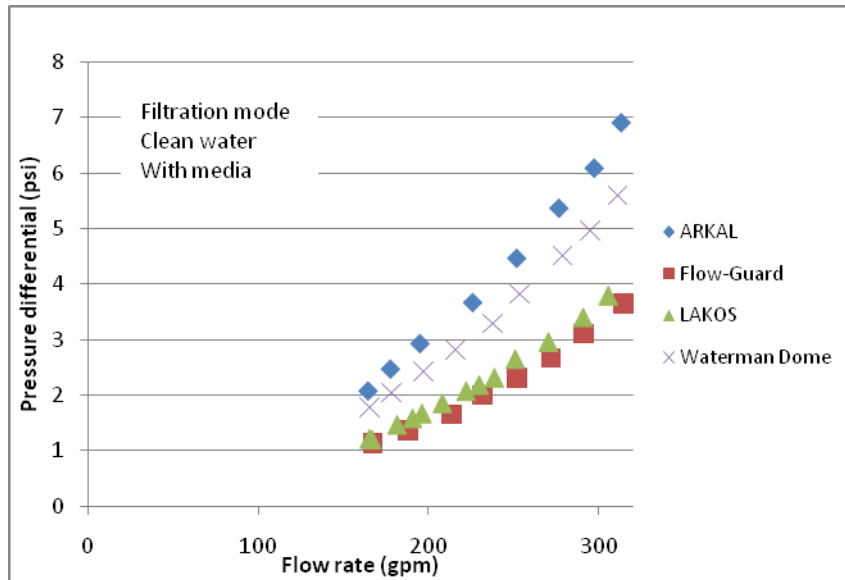

Figure 28. Total pressure loss across tanks with clean water and media – filtration mode

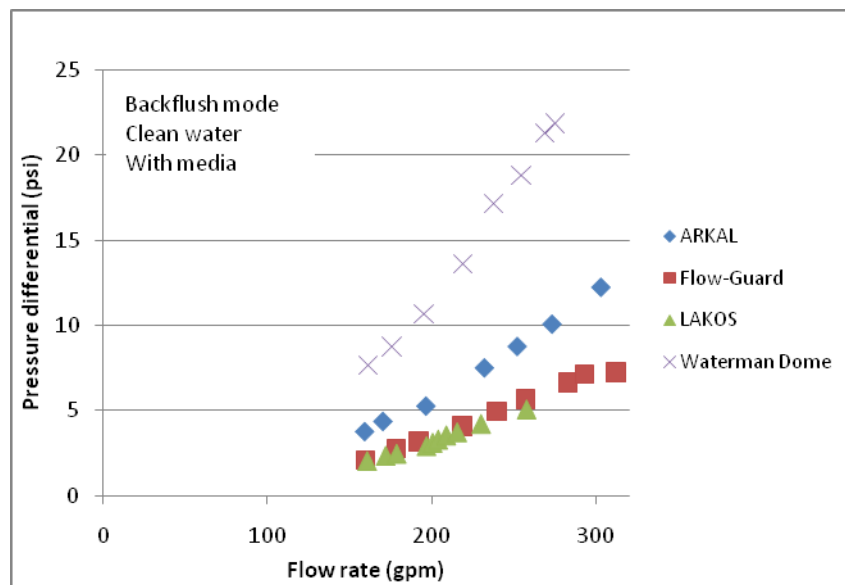

Figure 29. Total pressure loss across tanks with clean water and media – backflush mode

Activation Pressures and Times for Backflush Valves

Backflush valves are “hydraulic” valves and therefore depend on water flow into and out of a chamber that turns the flow on or off in one or more directions. If a backflush valve requires a high pressure to activate, it is possible that this high pressure may exceed all the other drip/micro irrigation system pressure requirements.

An additional question is how quickly a backflush valve opens and closes. A quick-opening backflush valve will enable the media tank to be cleaned with less water during backflush, because the high flow rate will be quickly established or stopped – without wasting water during the starting and stopping process.

The following physical arrangement was used to test the backflush valve actions. The arrangement put a pressure on both the inlet and “tank” sides of the valve at all times, and also allowed the inlet pressure to remain relatively constant during the on/off action.

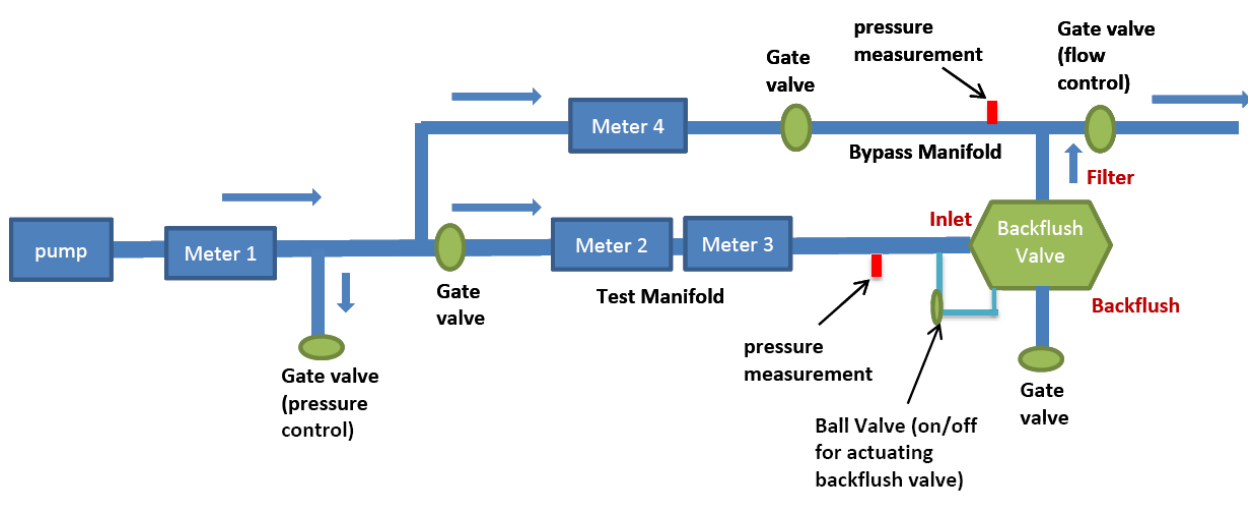

Figure 30. Schematic of the test setup with backflush valve closed

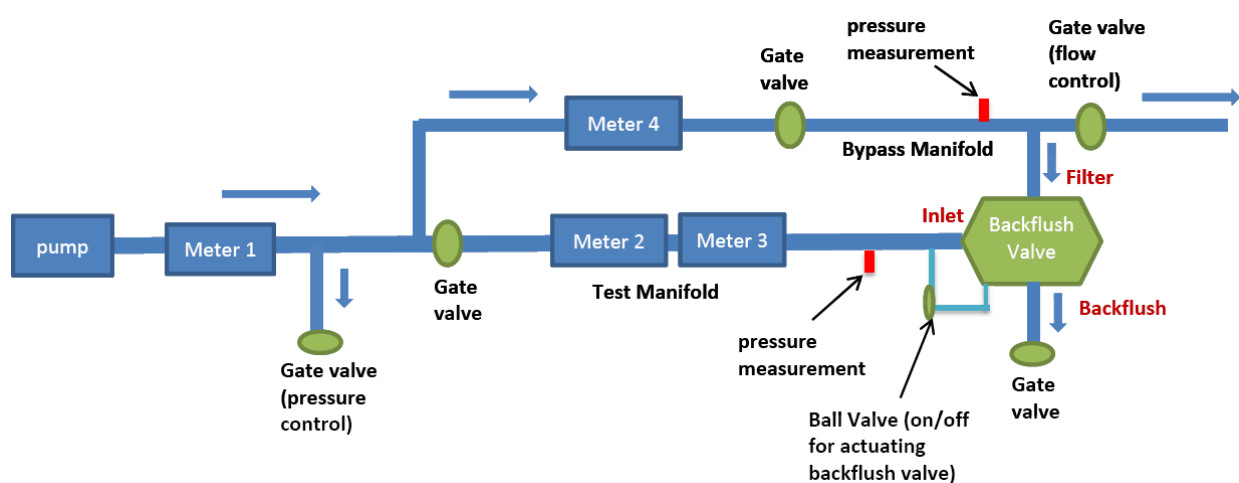

Figure 31. Schematic of the test setup with backflush valve open (actuated)

The test procedure was as follows:

1. Close bypass manifold valve.
2. Adjust flow control valve and pressure control valve for 5 or 6 psi and 250 GPM at the inlet of the test valve.
3. Open bypass manifold valve for 100 GPM through the bypass manifold.
4. Readjust flow control and pressure control valves to reestablish 5 psi and 250 GPM at the inlet of the test valve.
5. Record total flow rate, flow rates through the test and bypass manifolds, and pressure at the inlet and filter outlet of the test valve.
6. Open diaphragm pressure line to actuate the valve.
7. Record the time for the flow rate through the valve inlet to drop to 0 GPM.
8. Record final total flow rate, flow rates through the test and bypass manifolds, and pressure at the inlet and filter outlet of the test valve.
9. Repeat steps 1 – 8 at 6, 7, 8, 9, 10, 15, 20, and 25 psi.

The two Waterman valves were of the same design and brand. The Flow-Guard and Lakos valves appeared to have the same design (with different filter outlet diameters and possibly different manufacturers).

The valve closure time was measured for each of the filter backflush valves at a range of pressures between 5 psi and 25 psi. The Waterman valves actuated the quickest; at 5 psi the valves closed in 6.5 seconds and at 23 psi the valves closed in 4.5 seconds.

The Arkal valve actuated the slowest. The Arkal valve did not begin to close until 13 psi was reached in the inlet line. At 13 psi the valve closed in 25 seconds and at 25 psi the valve closed in 13 seconds. The Flow-Guard and LAKOS valves also closed slowly.

Table 5. Minimum and maximum backflush valve closure times and pressures

Valve	Minimum Pressure (psi)	Valve Closure Time at Min. P. (sec)	Maximum Pressure (psi)	Valve Closure Time at Max. P. (sec)	Average Final Flow (GPM)
Flow-Guard	5	33	23	7	0
LAKOS	6	29	24	9	33*
Waterman 1	5	7	22	4	0
Waterman 2	6	6	24	5	0
Arkal	13**	25	25	13	0

*Although the “valve closure time” is measured as the time for the flow through the inlet of the backflush valve to drop from 250 GPM to 0 GPM, for the LAKOS valve there was some leakage through the inlet (ranging from 30 GPM to 38 GPM) after the valve was actuated for each of the pressures tested.

** The Arkal backflush valve did not actuate below 13 psi.

VISUAL INSPECTION OF THE TOP OF THE MEDIA BED AFTER BACKFLUSH

During the initial media cleaning process, the top of the media beds were visually inspected. The intent was to observe obvious uneven (bumpy) surfaces, or distinct color patterns. Such observations indicate uneven backflush flow patterns. The figures below illustrate what was seen.



Figure 32. Arkal AGF-48" media bed after media cleaning



Figure 33. Flow-Guard media bed after media cleaning



Figure 34. Lakos media bed after media cleaning

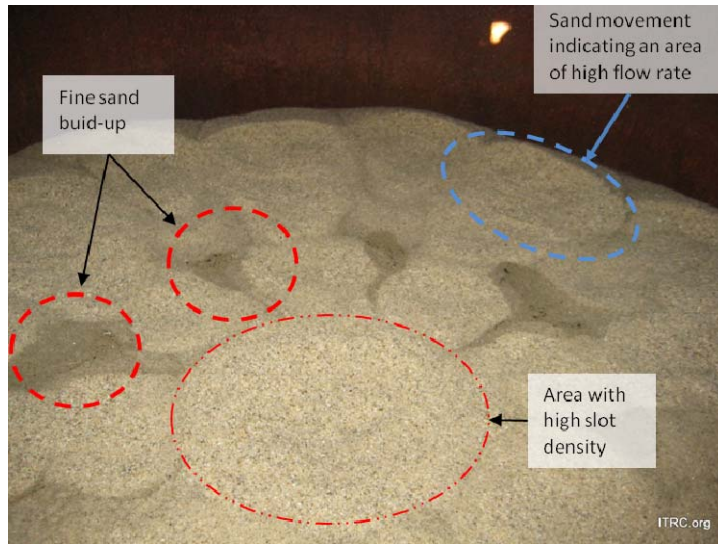

Figure 35. Waterman Wand ("spikes") bed after media cleaning



Figure 36. Waterman Dome bed after media cleaning

DISCHARGE OF MEDIA DURING BACKFLUSH

A general backflush flow recommendation for a 48” tank is about 190 GPM. Ideally, that would be evenly distributed through the media by the underdrain. If so, the velocities would be identical at all points at the top of the media. The average velocity of the water would be approximately 0.03 ft/sec.

ITRC measured the rate of fall through water of the #16 silica media that was used in tests. Ninety-nine percent of the #16 silica sand used had a settling velocity of greater than 0.12 ft/sec. This means that if the backflush flow rates were evenly distributed, one would not expect any media to be removed during backflushing.

It is common experience in the industry that high-than-recommended backflush flow rates have caused media to be removed. Little more than that general concept is commonly known.

During the media cleaning process, a nylon sock was held over the backflush discharge pipe to collect any media that was removed with a backflush duration of 2 minutes.

Table 6. Sand collected during backflush tests

Filter	Backflush flow rate (GPM)	Mass of sand collected in 2 minutes (gram)
Arkal	200	0
	250	0.2
Flow Guard	200	0.7
	250	48.6
Lakos (new)	200	0.7
	250	18.5
Waterman Dome	200	0.05
	250	2.2
Waterman Wand	200	0.0
	250	0.0

The flow rates in **Table 6** are higher than the 190 GPM or so that is typically recommended. The higher flow rate of 250 GPM was used to examine one aspect of backflush flow uniformity. At the commonly recommended backflush flow rate of 190-200 GPM, all the designs provide little/no media removal.



Figure 37. Examples of large amounts of media removed during backflush

TESTING WITH CONTAMINANTS

The most complicated and time-consuming aspect of the tank testing involved the injection of a combination of organic and inorganic materials into water that subsequently passed through the filter tanks. Because of the complexity and difficulties, only two tanks were tested – the Flow-Guard and Lakos tanks.

The filter backflush was controlled to start when the differential pressure was 4 psi greater than the clean total differential pressure at 250 GPM. Pressures and flows were continuously recorded. **Figure 38** illustrates a typical set of data.

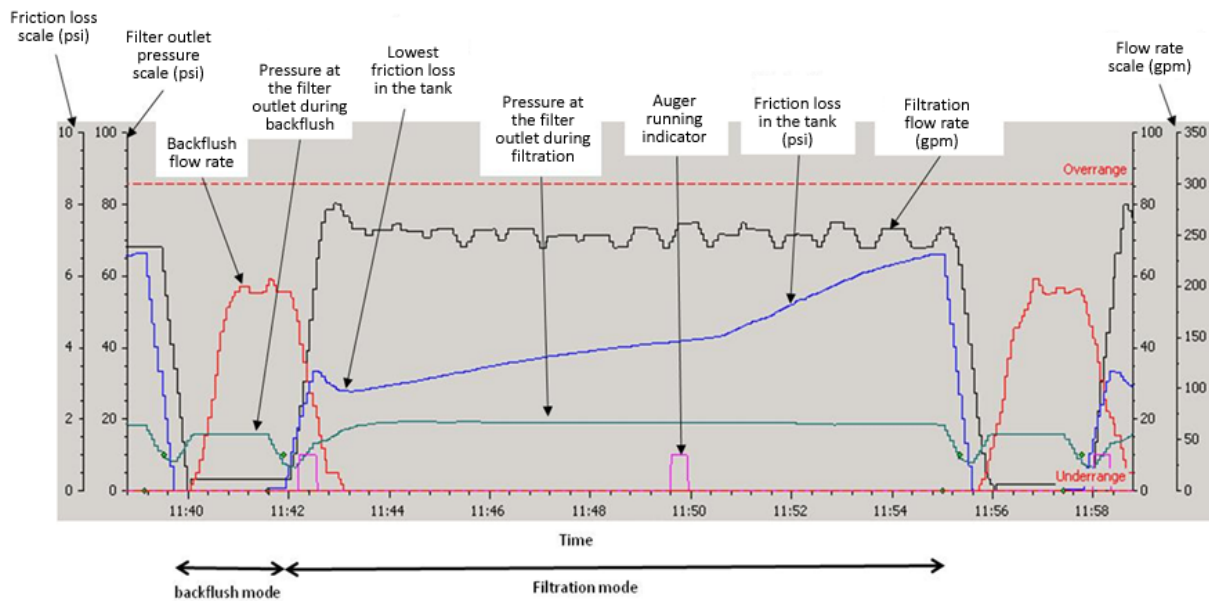

Figure 38. Example data collected during filtration with contaminant

Contaminant Description

A combination of soil and organic matter was used. The soil was collected from the bottom of an irrigation canal near Corcoran, California at the JG Boswell Farm, which has a high percentage of silt. The soil was separated into 5 piles, one bucket at a time, to ensure the creation of 5 similar treatment piles (although only 2 were eventually used).

The organic matter was ground manure from the Cal Poly compost facility. Contaminants were injected for 15 days, 8 hours/day.

Table 7. Contaminants injected during 15-day tests

	Lakos	Flow-Guard
Pounds of soil injected	432	432
Pounds of manure injected	264	264
Volume of water filtered (gallons)	1,501,700	1,543,100
Avg. ppm of contaminants	51	46

The first attempts at introducing organic matter utilized several potting soils that were purchased at Home Depot. There were two major problems that were immediately encountered:

1. The potting soil appeared to catch on the inlet dissipation screen in the Lakos unit (see **Figure 39**).
2. The potting soil layered the top of the media and built up, and was not removed with backflushing (see **Figure 40**).



Figure 39. Potting soil caught on inlet dissipation screen of the Lakos media tank. Flow-Guard has a similar dissipation screen, but was not tested with potting soil.

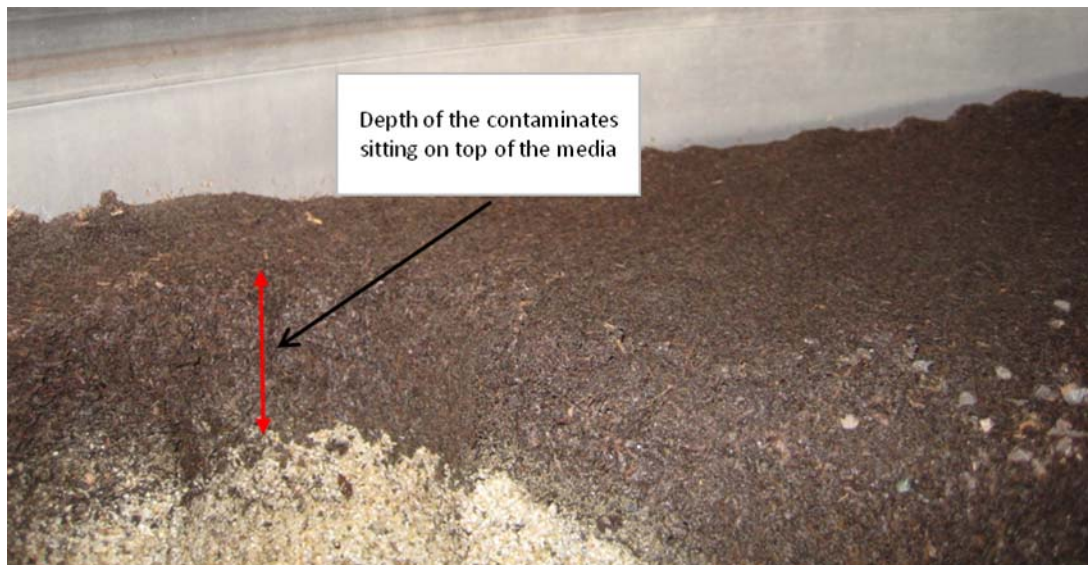

Figure 40. Potting soil that accumulated on the top of the media bed, even after repeated backflushing

The experience with potting soil clearly demonstrated the need for having adequate pre-filtration of water before it enters media tanks.

The weakest aspect of the contaminant testing was that the dirt injection mechanism was not continuous. Rather, an auger was activated over a 20-second period once every 7 minutes. The soil/manure mix was augered into a container that mixed it with water, and the mixture was subsequently pumped into the main supply pipe. The result was an injection of contaminants into the supply water for about 1 minute every 7 minutes. This certainly does not match standard injection conditions, although quite frequently media filters are subjected to bursts of contaminants.

In spite of this injection problem, the injection was consistent over the tests and consistent between the two tanks that were tested. Therefore, the results of the two tank tests are comparable. ITRC does not know if the results are completely realistic.

Backflushing of Contaminants

ITRC does not propose some new term such as “filtration efficiency” or “filtration effectiveness”. It can be stated that measurement of the discharge water quality for solids, during filtration, was inconclusive. That means that both the Flow-Guard and the Lakos filters were removing the solids. In that sense, they might well be considered to be very “efficient”.

The more challenging equation with media tank testing is to determine if the contaminants, once captured in the media, are removed during backflushing. Two measurements that might indicate the effectiveness of contaminant removal during backflushing include:

1. Do backflushing events become more frequent over time?
2. Can accumulated contaminants be measured throughout the media after the testing?

Frequency of backflushing. The two figures below show 17 days, although the time period of interest is 15 days. Some additional tests were run on the last 2 days.

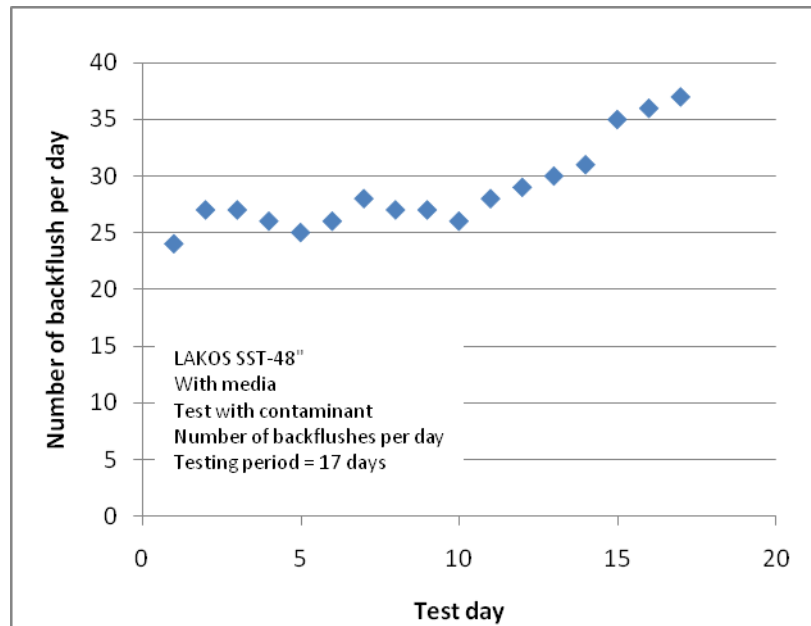

Figure 41. Number of backflashes per day – Lakos

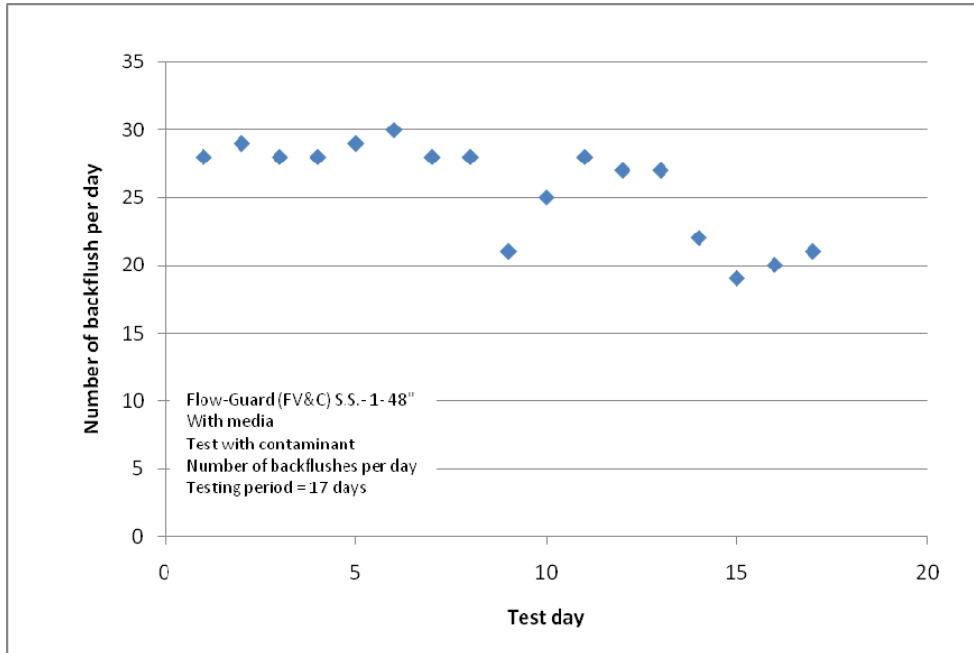

Figure 42. Number of backflashes per day – Flow-Guard

No measurements or observations conclusively showed why the trends are so different for the Lakos versus the Flow-Guard. In particular, it seems unusual that the Flow-Guard would backflush less often over time.

Contaminant Retained in the Media

After the extended injection of contaminants, samples of the media were collected in a pattern defined by a template, as shown in **Figure 43**.

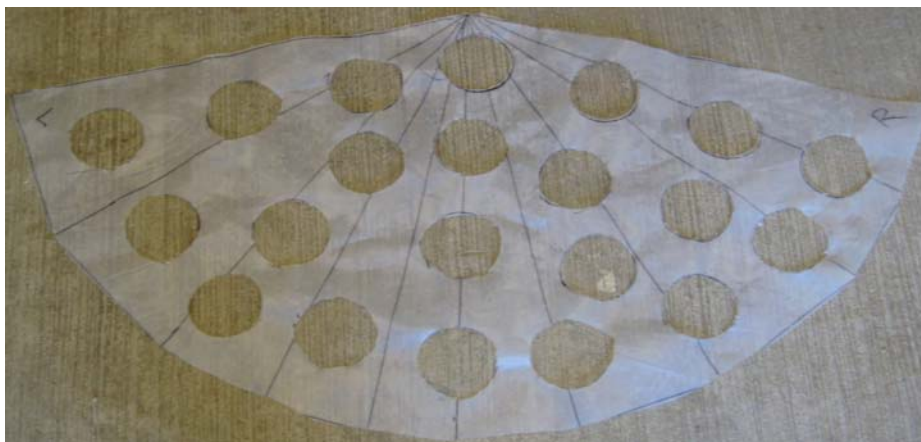

Figure 43. Plastic template used to position sampling cores across the top of the media



Figure 44. PVC cores forced 4” deep into each hole in the template, with collected soil

The media collection process was:

1. At the end of the test with contaminant (17 days) if the process ended in the middle of filtration mode, the backflush mode was run to make sure that all the tanks were in the same situation at the end of the test.
2. The tank was drained.
3. With the media inside still wet, the plastic sampling location layout was placed in the tank.
4. In each location a 3” PVC pipe was pushed four inches deep into the media.
5. The media and contaminants inside the PVC tube were collected.
6. The media collected in PVC cylinders was divided into two parts:
 - a. Small sample at the bottom of the cylinder, where there are no large contaminant particles
 - b. Large sample from the surface (the upper part of the sample), where there are large particles

The contaminants were separated from the media and tabulated as a percentage by weight for each sample. **Table 8** gives the results for the two tanks that were tested.

Table 8. Contaminant analysis from sand media

Filter	Top layer			Bottom layer		
	Percentage of Non-media	Standard deviation, %	cv	Percentage of Non-media	Standard deviation, %	cv
Flow-Guard	4.9	4.3	0.9	1.0	0.4	0.4
Lakos	12.0	3.9	0.3	3.1	2.6	0.8

BACKFLUSH PRESSURE VERSUS FLOW RATE

The backflush action of a media filter is dependent upon the backflush flow, not on the backflush pressure. **Figure 45** shows that the pressure at the bottom of a filter does not impact the backflush – as long as the flow rate is the same. For all three bottom pressures, the backflush flow rate was the same.

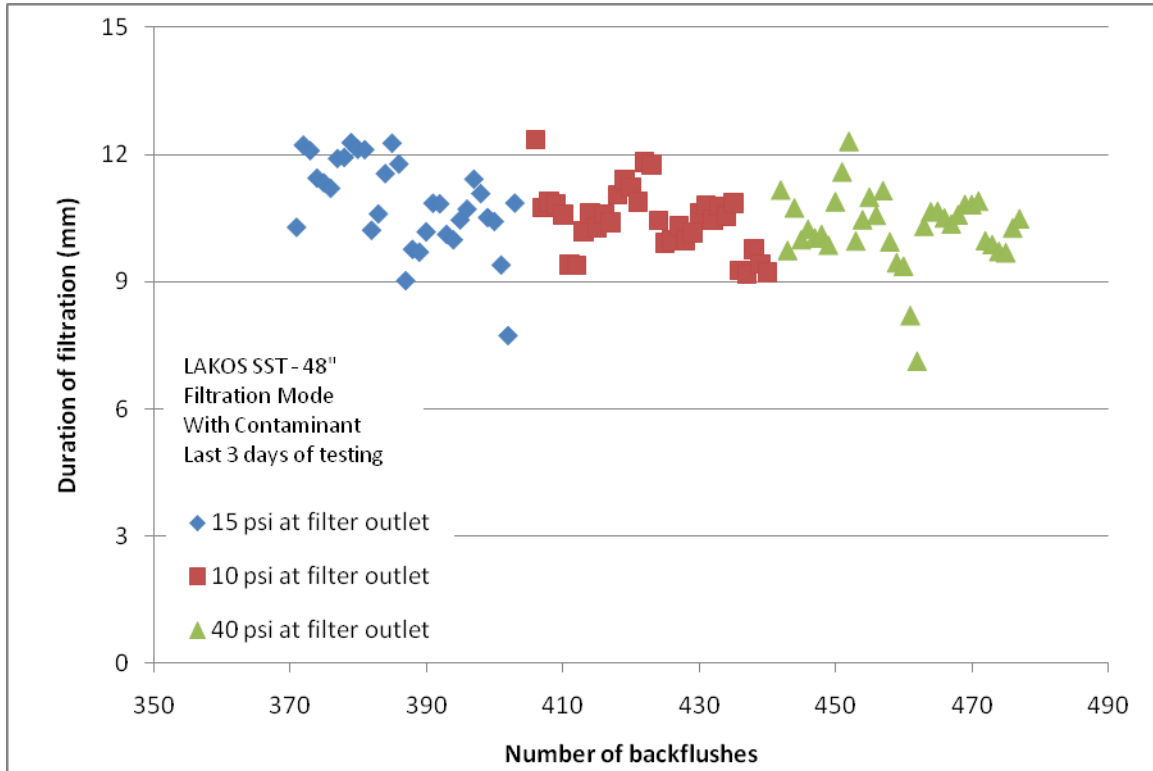

Figure 45. Duration of filtration compared to number of backflashes, showing that the pressure at the bottom of the filter does not impact dirt removal, if the flow rate remains constant

SUMMARIZED OBSERVATIONS

Most of the key physical characteristics are summarized below. In **Table 9**, the best values for each category are highlighted in blue; the lowest are highlighted in purple. The “Relative Importance” values are a very first attempt to designate which characteristics are more important than others. For example, a filter may receive a low rating for a characteristic that is not very important. Also, the various characteristics are not independent. For example, the amount of sand removal during backflush is highly dependent upon the design of the underdrain.

The reader should be aware that the specific values are not as important as the relative values. For example, if 40 grams of sand is removed during backflush, it is not really important if it was 45 or 35—if other units had almost no sand removal.

It is also clear that there are always some inaccuracies in measurement and small differences are not significant. A value of 0.8 psi friction for the Flow-Guard, and 0.9 psi for the Lakos valve were considered to be the same value by ITRC. Hence, both valves were given the same rating for that characteristic.

Table 9. Characteristics of the media filter tanks

Feature	Characteristic	Measured Values for Different Tanks						Relative Importance*
		Arkal	Flow-Guard	Lakos	Lakos New	Waterman Wand	Waterman Dome	
Valve	Friction during filtration with #16 silica media @250 GPM, psi	2.3	0.8	0.9		2.2	2.1	2.5
	Friction during backflush with #16 silica media @200 GPM, psi	5.0	3.0	2.8		11.5	11.5	5
	Pressure required to open, psi	13.0	5.0	6.0		5.0	6.0	5
	Valve closure time at 22-25 psi, sec.	13.0	7.0	9.0		4.0	5.0	6
System	Total friction loss during filtration @250 GPM when clean	4.3	2.2	2.5			3.6	3
	Total friction loss during filtration @200 GPM when clean	6.0	3.5	3.0			13.0	5
Sand Removal	Mass of sand (grams) in 2 minutes @250 GPM	0.2	48.6		18.5	0.0	2.2	10
	Mass of sand (grams) in 2 minutes @200 GPM	0.0	0.7		0.7	0.0	0.1	
Underdrain	Horizontal area (sq. cm.) served by each pod or wand unit	214	613	446		117	214	6
	Coefficient of variation of the horizontal area served per pod/wand unit	0.24	0.14	0.31		0.75	0.17	8
	% of the horizontal area that is covered by pods or wands	9	3	7		32	12	8
	Mean slot width, mm.	0.33	0.23		0.27	0.19	0.29	
	Std. Deviation of slot widths, mm.	0.036	0.029		0.036	0.026	Not meas.	5
	Total slot open area, sq. Cm.	200	184		261	343	108	5
Summary	Total best ratings	1	7	5		8	4	
	Total worst ratings	6	3	1		3	4	

*The greater the Relative Importance value, the more important this characteristic is.

What is apparent from **Table 9** is that none of the units was consistently the best or the worst. Each had advantages and disadvantages.

Some summary points are:

1. Some manufacturers have backflush valves with small flow passageways that require a high backflush pressure to achieve a recommended backflush flow rate.
2. Some manufacturers have backflush valves that have very little pressure loss during backflushing.
3. Although there are differences in friction loss through the media and through the underdrains of various manufacturers, this component of pressure loss is minor compared to the losses through some backflush valves.
4. Some backflush valves require high pressures to physically function properly.
5. This study found no good evidence that high pressures are needed for obtaining good backflushing of media filters if large backflush valves are used.
6. There are significant differences between models/manufacturers regarding many aspects of the underdrain designs, including:
 - a. Total open area of slots
 - b. Uniformity of slot widths
 - c. Percentage area of the horizontal area of a tank that is occupied by pods/wands
 - d. Uniformity of pod/wand placement horizontally
 - e. Uniformity of pond/wand placement vertically
7. A visual inspection of the tops of media beds after backflushing showed that there was non-uniform backflushing by all tanks.
8. A very uniform backflush through #16 silica media should cause almost no removal of media at 190 GPM, because the settling velocity of the media is about 4 times greater than the upward velocity of the water. The amount of backflushed media at a relatively high backflush rate (250 GPM) gives one simple and clear indication of the uniformity of backflush – or at least of the existence of some localized zones with very high velocities.
9. The partial plugging of the inlet flow dissipaters, and the lack of removal of bark-like contaminant during backflush, are clear indicators of the importance of adequate pre-filtration upstream of media tanks.

ENERGY IMPLICATIONS

1. Common industry opinion is that media tanks require at least 30-40 psi to operate properly. This is a significantly higher pressure than what is required for most row crop drip (i.e., tape) irrigation systems. Many row crop drip systems can be designed to operate at about 20 psi, not including the filter pressure requirements. In other words, a 30-40 psi requirement for filtration will determine the pump discharge pressure requirement.
2. The research presented in this report indicate that backflush valves (during the backflush mode) can be the major cause of a pressure drop during backflushing. Therefore, the following guidelines are recommended for the backflush valves of 48" media tanks:
 - a. Backflush valves should have no more than 5 psi loss during backflushing at 200 GPM
 - b. Backflush valves should require no more than 6 psi to operate properly – in other words, to securely seat in the backflush position with no leakage. If more pressure is required, that pressure should be supplied by a different pressure supply – one that is only actuated during backflush for the small flow rates needed to activate the valves.
 - c. Backflush valves should activate in both directions in less than 4 seconds at 25 psi, and in no more than 8 seconds at 15 psi.
3. It is common lore in the irrigation industry that a high pressure is needed for backflushing if the media beds plug up. It appears from this research, although it is not proven, that a non-uniform backflush flow through the media tank can cause much of the media to be ineffective. Therefore, it is hypothesized that a very uniform backflush will reduce problems with plugging up of the media beds. Continuing with this logic, if the media beds do not plug up, there is no need for a high pressure “on standby” to unplug a dirty media bed.
4. A uniform backflush of the media bed will provide better cleaning of the media and less gradual buildup of contaminant in poorly fluidized zones. More uniform backflushing should eventually result in less backflush volume per volume of water filtered, which in turn saves the energy associated with pumping that extra backflush water.
5. To minimize the pressure needed for backflushing, designers and installers must consider at least three other points. Prior experience by ITRC points to these common problems:
 - a. The backflush water disposal pipelines may be poorly designed and restrict the backflush flow. Typical errors include not using large enough diameters, having long pipelines, and not including adequate air release valves in the backflush pipeline.
 - b. The backflush timing and flows (frequency, duration, flow rate) may be improperly adjusted. This can result in a “caking up” or “plugging up” of the media that requires either mechanical agitation or a very high pressure to break up.
 - c. Only two tanks are used. If only two tanks are used, the friction loss through the one functional tank (i.e., the tank that must filter the backflush water for the other tank, plus supply the irrigation system) can easily be 3-4 times the normal operating friction loss. Assuming that the tanks are set to backflush at a 6 psi differential, this means that during backflush the one flowing tank may have an 18-24 psi friction loss across it.

This report was prepared as part of CEC Contract Number 500-06-040.

LEGAL NOTICE

"THIS REPORT WAS PREPARED AS A RESULT OF WORK SPONSORED BY THE CALIFORNIA ENERGY COMMISSION (COMMISSION). IT DOES NOT NECESSARILY REPRESENT THE VIEWS OF THE COMMISSION, ITS EMPLOYEES, OR THE STATE OF CALIFORNIA. THE COMMISSION, THE STATE OF CALIFORNIA, ITS EMPLOYEES, CONTRACTORS, AND SUBCONTRACTORS MAKE NO WARRANTY, EXPRESS OR IMPLIED, AND ASSUME NO LEGAL LIABILITY FOR THE INFORMATION IN THIS REPORT; NOR DOES ANY PARTY REPRESENT THAT THE USE OF THIS INFORMATION WILL NOT INFRINGE UPON PRIVATELY OWNED RIGHTS. THIS REPORT HAS NOT BEEN APPROVED OR DISAPPROVED BY THE COMMISSION NOR HAS THE COMMISSION PASSED UPON THE ACCURACY OR ADEQUACY OF THE INFORMATION IN THIS REPORT."

This report was prepared as part of CEC Contract Number 500-06-040.

LEGAL NOTICE

"THIS REPORT WAS PREPARED AS A RESULT OF WORK SPONSORED BY THE CALIFORNIA ENERGY COMMISSION (COMMISSION). IT DOES NOT NECESSARILY REPRESENT THE VIEWS OF THE COMMISSION, ITS EMPLOYEES, OR THE STATE OF CALIFORNIA. THE COMMISSION, THE STATE OF CALIFORNIA, ITS EMPLOYEES, CONTRACTORS, AND SUBCONTRACTORS MAKE NO WARRANTY, EXPRESS OR IMPLIED, AND ASSUME NO LEGAL LIABILITY FOR THE INFORMATION IN THIS REPORT; NOR DOES ANY PARTY REPRESENT THAT THE USE OF THIS INFORMATION WILL NOT INFRINGE UPON PRIVATELY OWNED RIGHTS. THIS REPORT HAS NOT BEEN APPROVED OR DISAPPROVED BY THE COMMISSION NOR HAS THE COMMISSION PASSED UPON THE ACCURACY OR ADEQUACY OF THE INFORMATION IN THIS REPORT."